

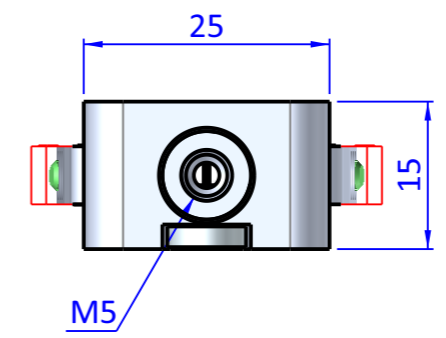

THE PROPERTY OF THE DRAWING IS ESTABLISHED BY LAW. IT IS FORBIDDEN TO PRODUCE OR SHOW IT TO THIRD PART. WITHOUT A WRITTEN AGREEMENT.

Item	Name	Qty.
1	A.ELA.RA1.9	2
2	CA.08.14.013	1
3	GZA.10.12.1.18	1
4	GZA.10.12.2.OR	2
5	GZA.10.12.3.G	2
6	GZA.10.12.6.V	2
7	GZA.10.12.9	2
8	M.6x25.SH	1
9	SP.3x15SS	2

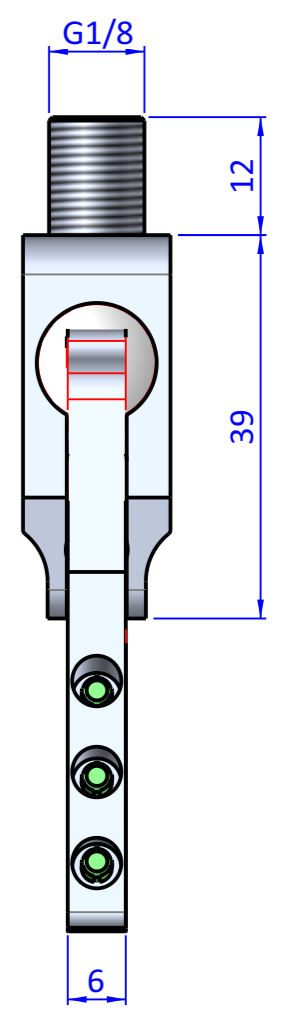
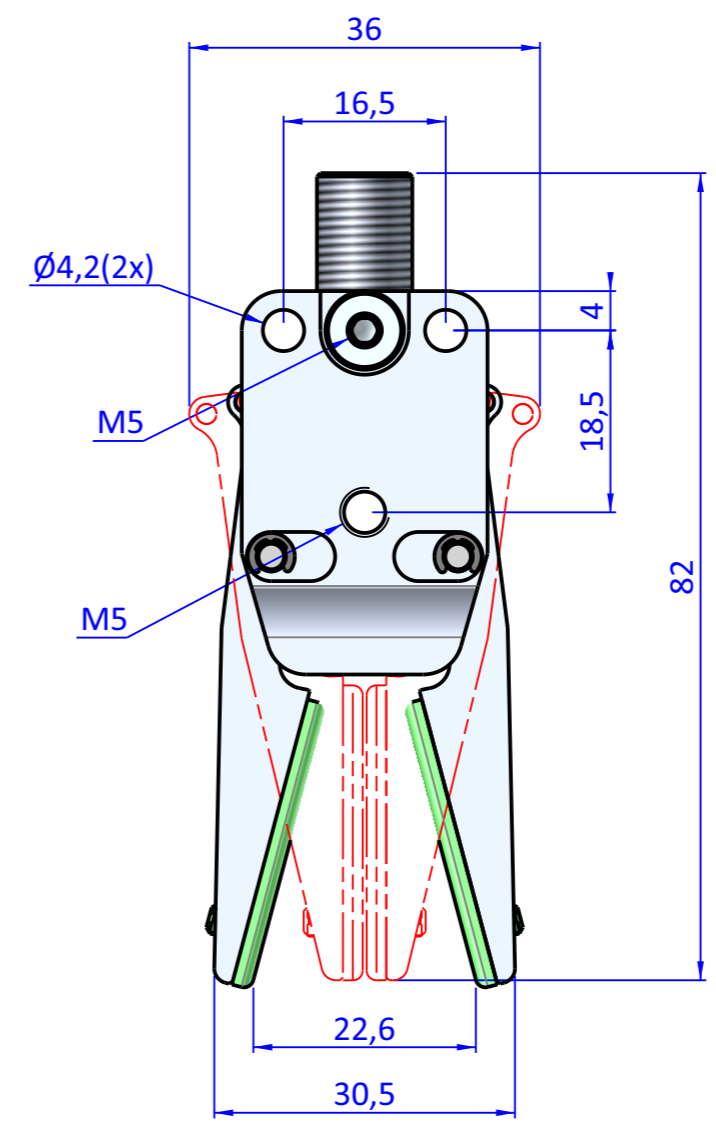
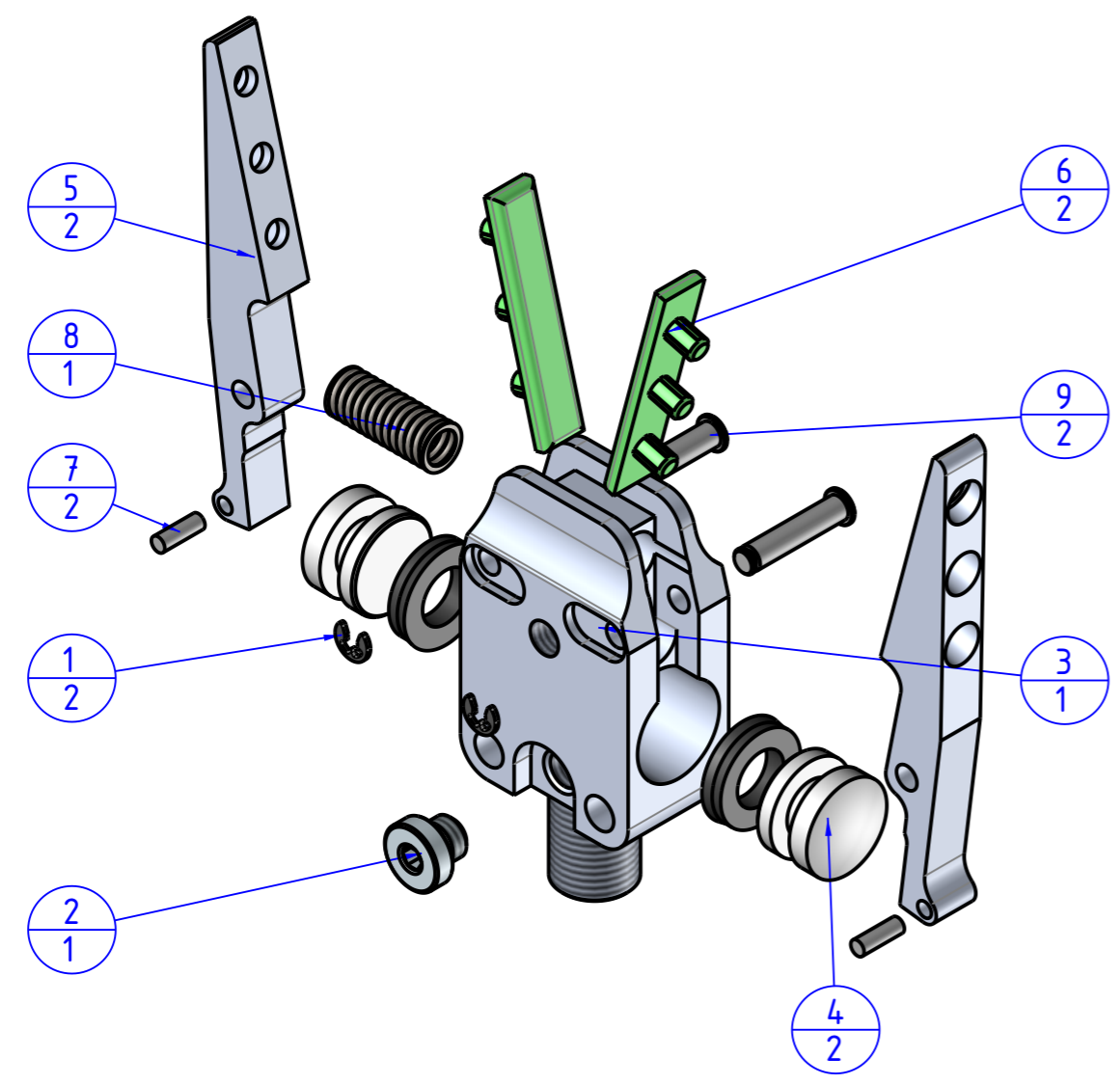

Format A3  
UNI 936-76

 <b>FPS</b> FPSERVICES AUTOMATION		DESIGNED FROM		REVIEW
		FPS Automation		A
GENERAL TOLERANCE		DATE	WEIGHT	
UNI - ISO 2768		09/04/2026	0,037kg	
CLASSE f		DESCRIPTION	CODE	
		CA.GZA.10.12.G18	CA.GZA.10.12.G18	